

SSD1961/2/3

Application Note for SSD1961/2/3

This document contains information on a product under definition stage. Solomon Systech reserves the right to change or discontinue this product without notice.

<http://www.solomon-systech.com>

SSD1961

Rev 1.7

P 1/28

Jan 2013

Copyright © 2013 **Solomon Systech Limited**



CONTENTS

1	INTRODUCTION	5
2	HARDWARE CONNECTION	6
2.1	HARDWARE OVERVIEWS	6
2.2	CONNECTION TO MCU (8080 AND 6800 INTERFACE)	8
2.3	CONNECTION TO LCD PANEL	11
2.4	REFERENCE APPLICATION CIRCUIT	14
3	PROGRAMMING EXAMPLE	15
3.1	POWER UP INITIALIZATION FOR VGA PANEL	15
3.2	ADDITION SETTING FOR SERIAL RGB PANEL	19
3.3	DEEP SLEEP MODE	21
3.4	WAKE UP.....	21
4	DYNAMIC BACKLIGHT CONTROL	22
4.1	HARDWARE REQUIREMENT	23
4.2	PROCEDURES FOR SETTING UP DBC	24
5	USE GPIO AS SPI SIGNALS	26
5.1	PROCEDURE TO SETUP THE GPIO	26
6	USE GPIO AS MISC SIGNALS	29
6.1	PROCEDURE TO SETUP THE GPIO	30
7	EXAMPLE FOR ROTATION DISPLAY	33

TABLES

TABLE 2-1: CONNECTION BETWEEN SSD1961/2/3 AND MCU..... 10
TABLE 2-2: CONNECTION BETWEEN SSD1961 AND TD028TTEC1 LCD PANEL 13
TABLE 4-1: EXAMPLES OF PROGRAMMING VALUE.....25

FIGURES

FIGURE 2-1: APPLICATION EXAMPLE OF SSD1961/2	6
FIGURE 2-2: APPLICATION EXAMPLE OF SSD1963	7
FIGURE 2-3: SSD1961/2 INTERFACES TO MCU (8080 INTERFACE)	8
FIGURE 2-4: SSD1963 INTERFACES TO MCU (8080 INTERFACE)	9
FIGURE 2-5: SSD1961/2 INTERFACES TO MCU (6800 INTERFACE)	9
FIGURE 2-6: SSD1963 INTERFACES TO MCU (6800 INTERFACE)	9
FIGURE 2-7: TD028TTEC1 LCD PANEL INTERFACES TO SSD1961	11
FIGURE 2-8: SERIAL RGB LCD PANEL INTERFACES TO SSD1961/2/3	12
FIGURE 3-1 : VERTICAL TIMING OF TD028TTEC1	16
FIGURE 3-2 : HORIZONTAL TIMING OF TD028TTEC1	16
FIGURE 4-1 : POWER COMPARISON OF DBC	22
FIGURE 4-2: DBC EXAMPLE - ORIGINAL IMAGE	23
FIGURE 4-3: DBC EXAMPLE - CONSERVATIVE MODE (19% BACKLIGHT SAVED)	23
FIGURE 4-4: DBC EXAMPLE - NORMAL MODE (31% BACKLIGHT SAVED)	23
FIGURE 4-5: DBC EXAMPLE - AGGRESSIVE MODE (50% BACKLIGHT SAVED)	23
FIGURE 4-6: EXAMPLE OF HARDWARE CONNECTION TO BENEFIT DBC	24
FIGURE 5-1: OUTPUT OF GPIO SIGNALS	26
FIGURE 7-1 : THE FIGURE ILLUSTRATES THE PANEL SCAN DIRECTION AND SSD196X MEMORY MAPPING	33

1 INTRODUCTION

The display trend of mobile applications is advancing from QVGA resolution to a much higher resolution such as HVGA, VGA, and beyond. However, interfacing between a processor to a higher resolution display panel module is not an easy task.

One of common disconnects is the interface of the processor versus the interface of the display panel module. The processor side usually comes with a 6800/8080-type of CPU interface which has a refresh rate of 30Hz and is often used to interface with a smart display panel module (i.e. a full frame buffer embedded inside the display driver IC). This is only possible if the targeted application is only for QVGA and below. When it comes to HVGA, VGA, or even higher resolution, the frame buffer is usually too large to be integrated inside the LCD driver due to the physical limitation of the glass that limits the aspect ratio of the LCD driver IC. Thus, the commonly found display panels at higher resolution are a dumb panel type (i.e. without a frame buffer). The interface is usually a digital RGB interface with a refresh rate of around 60Hz.

Even if the processor comes with an RGB interface, there could still have another potential issue – a much higher data throughput to be supported by the processor which might impact the performance of other features. A use case scenario of a video file playback will illustrate this idea. In this scenario, a few operations such as the operating system, file parsing, video decoding, audio decoding, color space conversion, and resizing are working simultaneously with the LCD controller. These operations are fighting for bus bandwidth against the LCD controller. When rotation is involved, this situation is even worsened.

To tackle these issues, SSD1961/2/3 display controller is designed to offer a cost-effective and a simple-to-integrate solution to the existing platforms without requiring a major overhaul of the hardware and software. In addition, an advanced Dynamic Backlight Control (DBC) algorithm is also built-in as an extra value to significantly save the power consumption of the LED backlight of the display module without sacrificing the display quality.

SSD1961/2/3 offers the following competitive advantages.

1. Conversion of 6800/8080-type CPU interface at 30fps or below to RGB interface at 60fps.
2. A full frame buffer is integrated. The processor can be shut down to save power while SSD1961/2/3 is still able to refresh the display.
3. Hardware display rotation, mirroring and windowing.
4. Minimum of 2 times reduction of data throughput requirement from the processor.
5. Tearing output signal to synchronize the incoming data with the display data.
6. Dynamic Backlight Control for LED backlight power saving.

This application note serves to provide easy-to-follow instructions by illustrating the connections to SSD1961/2/3 with the MediaTek baseband processor via the microcontroller interface and with the LCD display panel via the RGB interface. A sample initialization code is provided for reference to show how to program SSD1961/2/3 at initial stage and how to put SSD1961/2/3 into deep sleep mode. The Dynamic Backlight Control (DBC) feature is also explained.

2 HARDWARE CONNECTION

2.1 Hardware Overviews

To connect a dump panel to MCU through its smart panel interface, SSD1961/2/3 serves as a bridge to be connected as shown in Figure 2-1 and Figure 2-2.

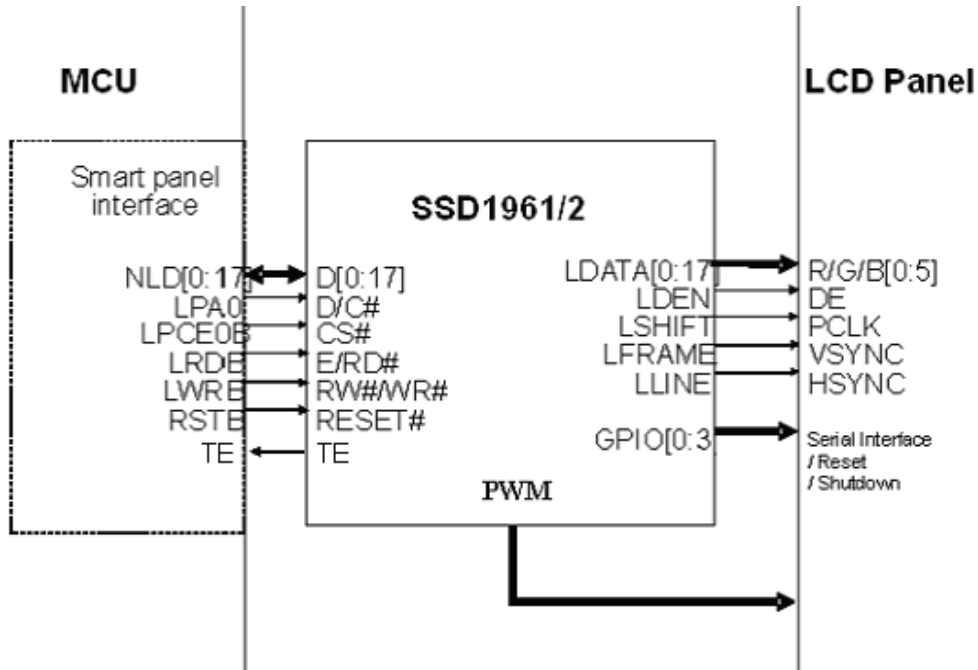

Figure 2-1: Application example of SSD1961/2

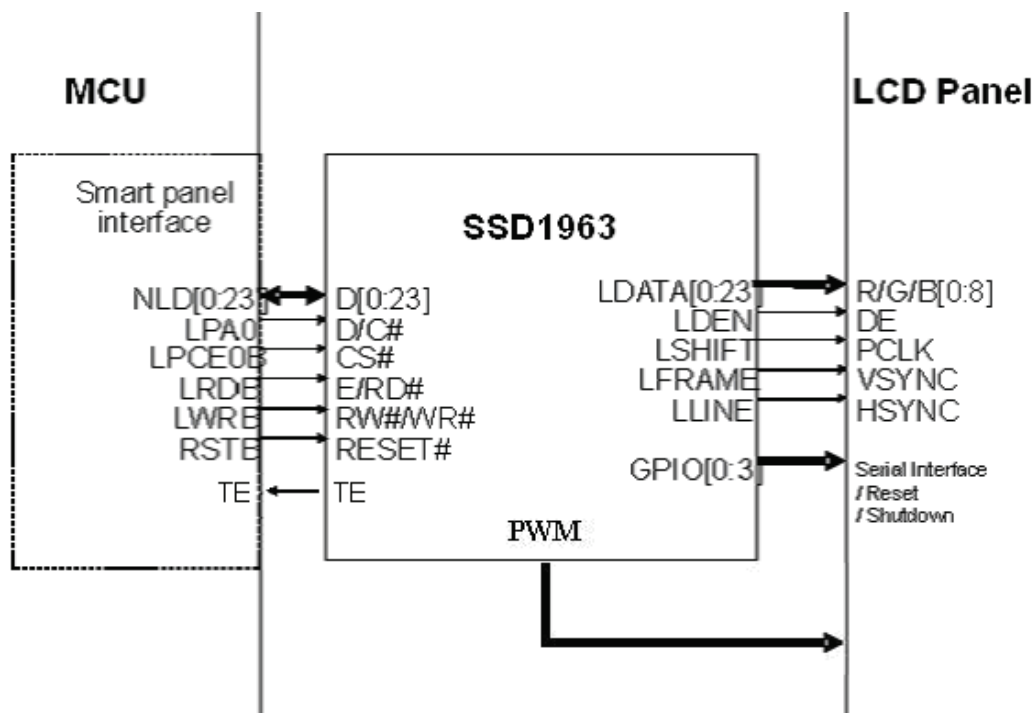

Figure 2-2: Application example of SSD1963

2.2 Connection to MCU (8080 and 6800 interface)

If the CONF pin is connected to VDDIO, the MCU interface will be configured in 8080 mode interface. Figure 2-3 and Figure 2-4 illustrates how SSD1961/2/3 interfaces to MCU (8080 interface) smart panel interface.

If the CONF pin is connected to VSSIO, the MCU interface will be configured as 6800 mode interface. Figure 2-5 and Figure 2-6 illustrates how SSD1961/2/3 interfaces to MCU (6800 interface) smart panel interface.

Table 2-1 explains in details for signal connections.

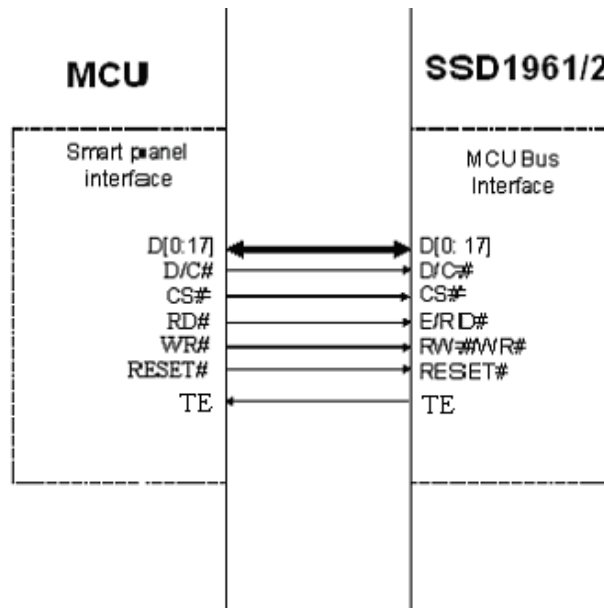

Figure 2-3: SSD1961/2 interfaces to MCU (8080 interface)

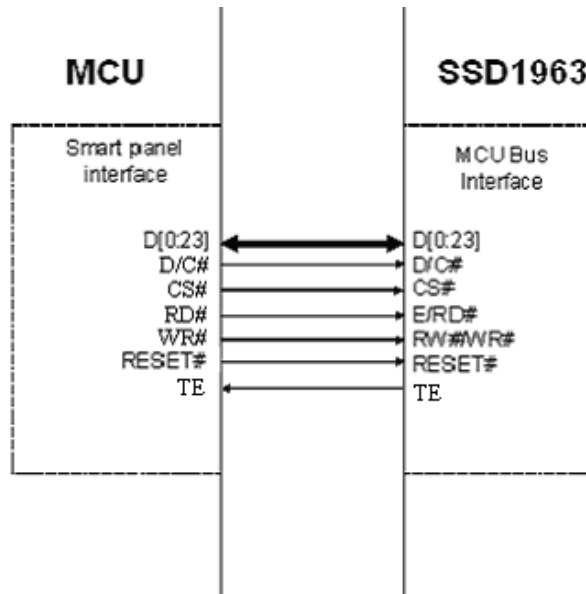

Figure 2-4: SSD1963 interfaces to MCU (8080 interface)

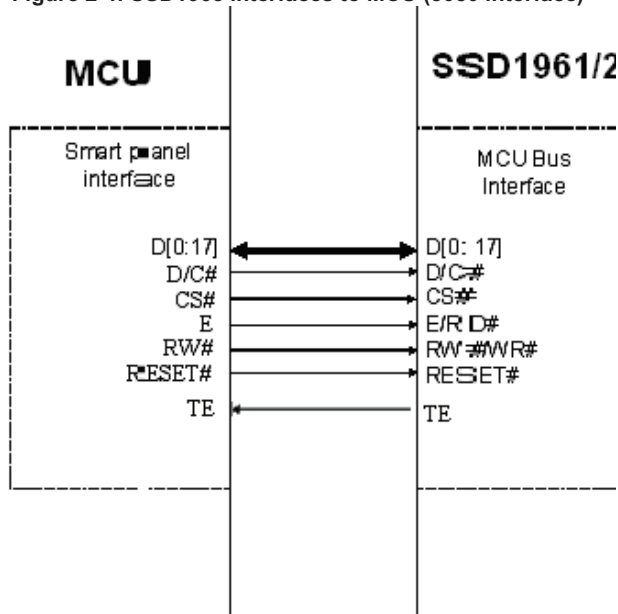

Figure 2-5: SSD1961/2 interfaces to MCU (6800 interface)

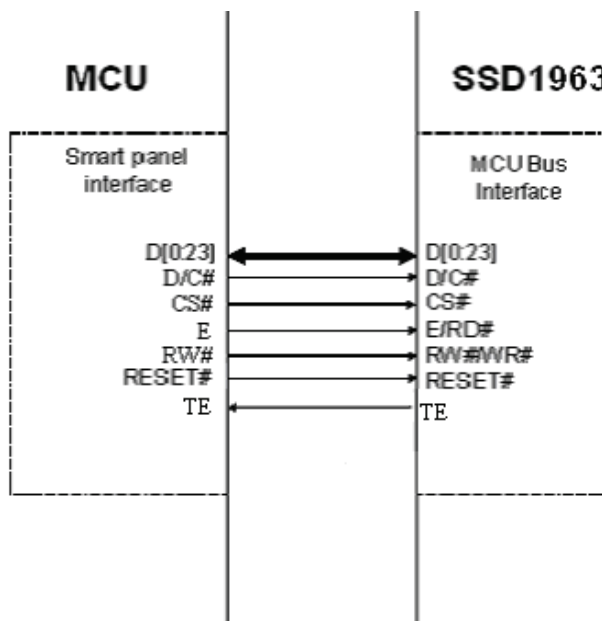

Figure 2-6: SSD1963 interfaces to MCU (6800 interface)

MCU Pin Name		SSD1961/2/3 Pin Name	Description
(6800 interface)	(8080 interface)		
D[0:17] / D[0:23]	D[0:17] / D[0:23]	D[0:17] for SSD1961/2 D[0:23] for SSD1963	Data bus connection
D/C#	D/C#	D/C#	High assert indicates for a DATA presenting on the data bus, while low assert indicates for a COMMAND presenting on the data bus
RW#	WR#	R/W# (WR#)	For 6800 : High indicate read cycle and low indicate write cycle For 8080 : Active low write enable
E	RD#	E(RD#)	For 6800 : Enable signal For 8080 : Active low read enable
CS#	CS#	CS#	Active low chip select
RESET#	RESET#	RESET#	Active low reset signal

Table 2-1: Connection between SSD1961/2/3 and MCU

2.3 Connection to LCD panel

SSD1961/2/3 contains a RGB LCD controller and multi-purpose GPIOs capable to drive an 18/24 bit RGB LCD panel. Figure 2-7 illustrates the connection between SSD1961 to TPO TD028TTEC1 LCD panel and Table 2-2 explain in detail for each signal connection.

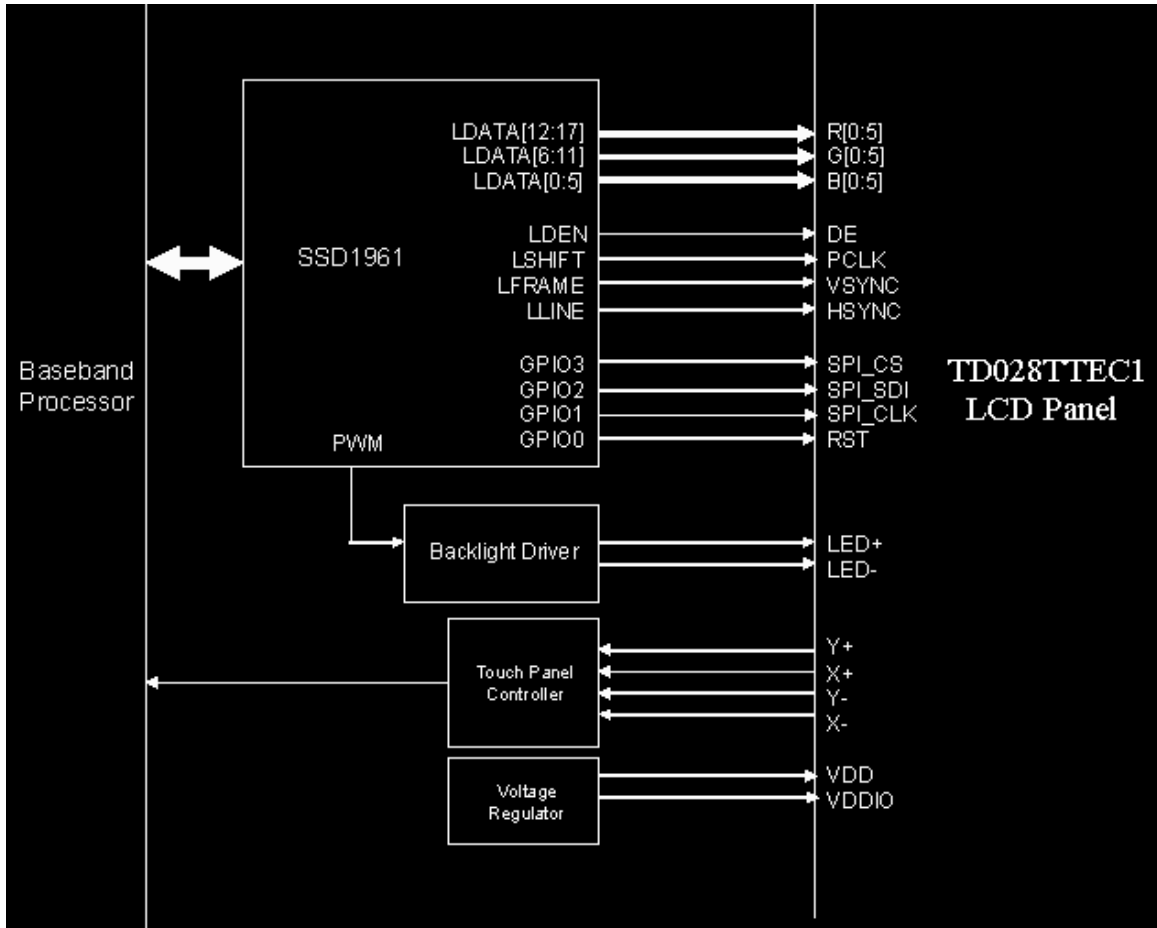

Figure 2-7: TD028TTEC1 LCD panel interfaces to SSD1961

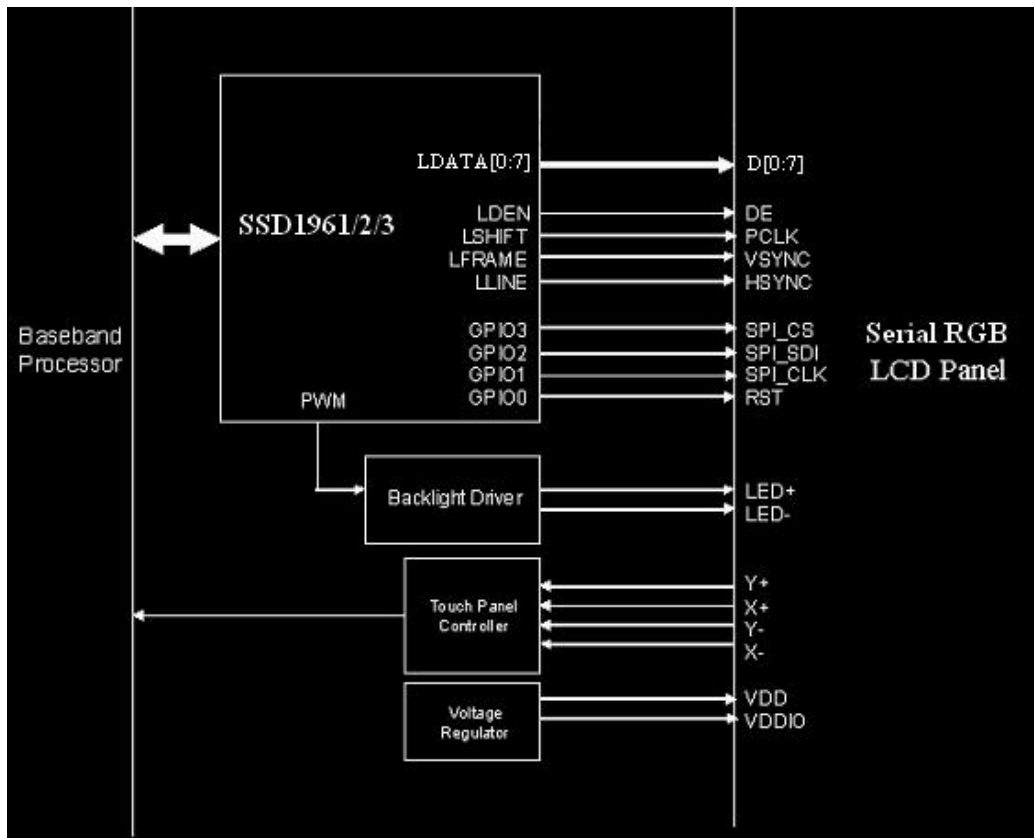
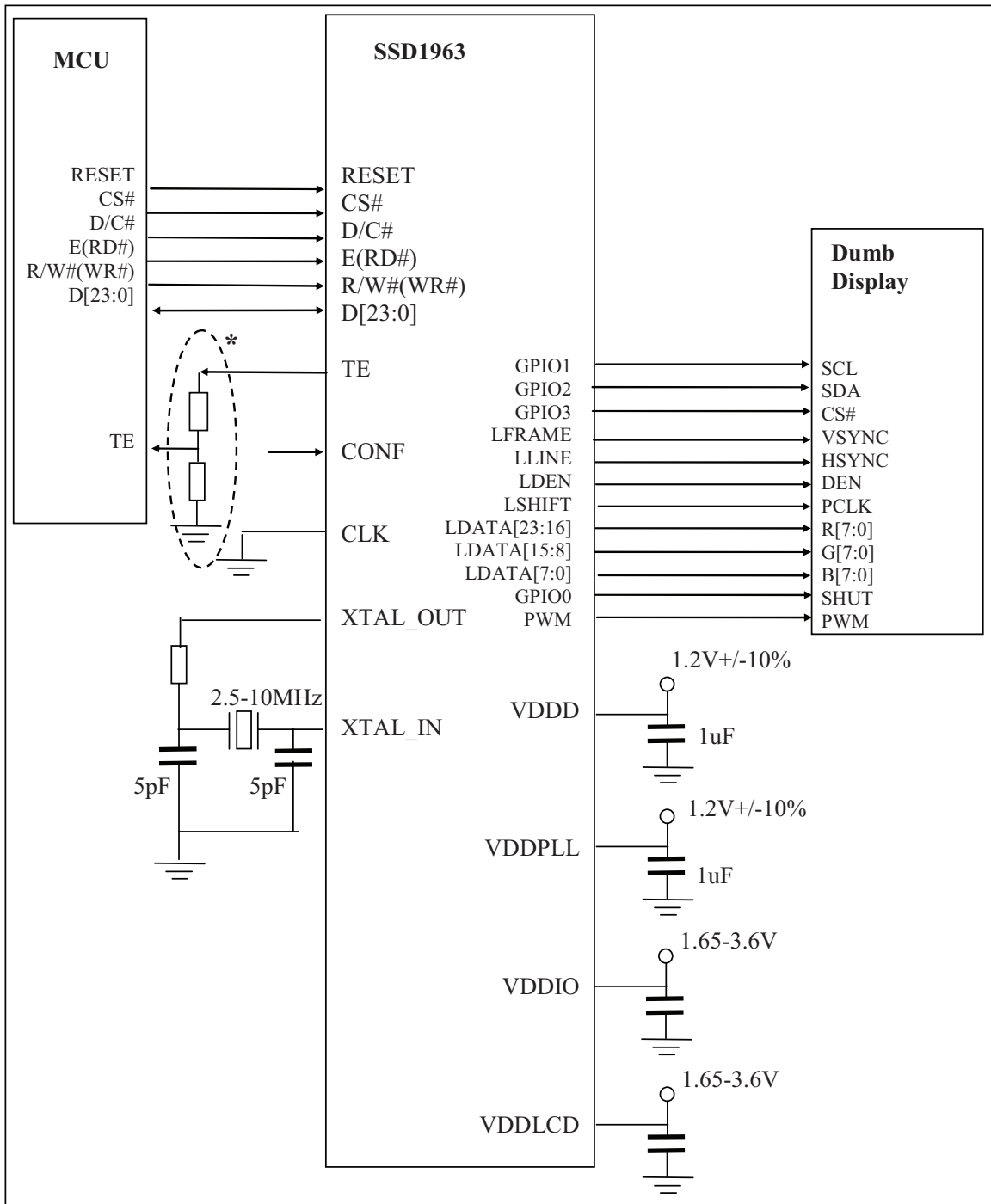

Figure 2-8: Serial RGB LCD panel interfaces to SSD1961/2/3

TPO LCD Panel		Connection	Description
Pin Number	Pin Name		
1	LED+	Backlight Regulator	Backlight LED Anode
2	LED-	Backlight Regulator	Backlight LED Cathode
3	VDD IO	Power Regulator	I/O Power Input
4	VDD	Power Regulator	Power Input
5	GND	Ground	GND
6	Y+	Touch Panel Controller Y Upper	Touch Panel Y Upper
7	X+	Touch Panel Controller X Left	Touch Panel X Left
8	Y-	Touch Panel Controller Y Lower	Touch Panel Y Lower
9	X-	Touch Panel Controller Right	Touch Panel X Right
10	SPI_CS	SSD1961 GPIO3	Serial Data Chip Select
11	SPI_SDI	SSD1961 GPIO2	Serial Data Input
12	GND	Ground	Ground
13	SPI_CLK	SSD1961 GPIO1	Serial Data Clock
14	NC	No Connection	No Connection
15	RST	SSD1961 GPIO0	LCD Reset
16	B0	SSD1961 LDATA0	Blue Data Bit 0
17	B1	SSD1961 LDATA1	Blue Data Bit 1
18	B2	SSD1961 LDATA2	Blue Data Bit 2
19	B3	SSD1961 LDATA3	Blue Data Bit 3
20	B4	SSD1961 LDATA4	Blue Data Bit 4
21	B5	SSD1961 LDATA5	Blue Data Bit 5
22	G0	SSD1961 LDATA6	Green Data Bit 0
23	G1	SSD1961 LDATA7	Green Data Bit 1
24	G2	SSD1961 LDATA8	Green Data Bit 2
25	G3	SSD1961 LDATA9	Green Data Bit 3
26	G4	SSD1961 LDATA10	Green Data Bit 4
27	G5	SSD1961 LDATA11	Green Data Bit 5
28	R0	SSD1961 LDATA12	Red Data Bit 0
29	R1	SSD1961 LDATA13	Red Data Bit 1
30	R2	SSD1961 LDATA14	Red Data Bit 2
31	R3	SSD1961 LDATA15	Red Data Bit 3
32	R4	SSD1961 LDATA16	Red Data Bit 4
33	R5	SSD1961 LDATA17	Red Data Bit 5
34	GND	Ground	Ground
35	PCLK	SSD1961 LSHIFT	Pixel Clock
36	GND	Ground	Ground
37	VSYNC	SSD1961 LFRAME	Vertical Sync
38	HSYNC	SSD1961 LLINE	Horizontal Sync
39	DE	SSD1961 LDEN	Data Enable

Table 2-2: Connection between SSD1961 and TD028TTEC1 LCD panel

2.4 Reference application circuit



* If IO voltage of the MCU is lower than the LCD voltage, TE signal need to rectify before applies to the MCU IO voltage in order to prevent MCU damage by the voltage difference.

3 PROGRAMMING EXAMPLE

This section introduces 3 critical programming sequences for SSD1961/2/3. Section 3.1 provide an example on power up initialization, Section 3.3 provide sample code to put SSD1961/2/3 into deep sleep mode and Section 3.4 shows how to wake up SSD1961/2/3 from deep sleep mode.

3.1 Power Up Initialization for VGA panel

Power-up programming is required before using SSD1961/2/3 to display images. The following steps show an example to connect SSD1961 with a 480x640 (VGA) LCD panel - TPO TD028TTEC1.

Horizontal Total, HT = 520
Horizontal Width, HDISP = 480
Horizontal Front Porch, HFP = 24
Horizontal Back Porch, HBP = 8
Horizontal Pulse Width, HS = 8

Vertical Total, VT = 648
Vertical Width, VDISP = 640
Vertical Front Porch, VFP = 4
Vertical Back Porch, VBP = 2
Vertical Pulse Width, VS = 2

Frame Rate = 65Hz
Pixel clock = 22MHz
Input clock = 10MHz

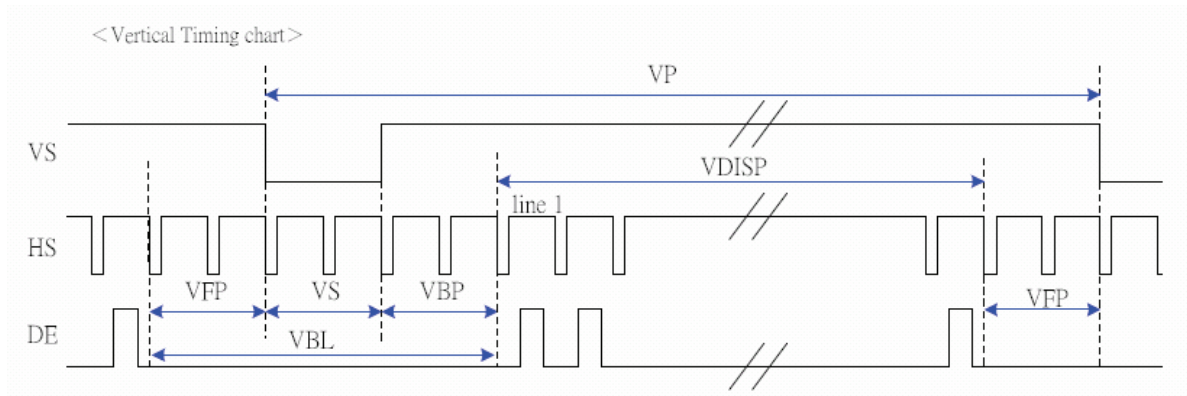
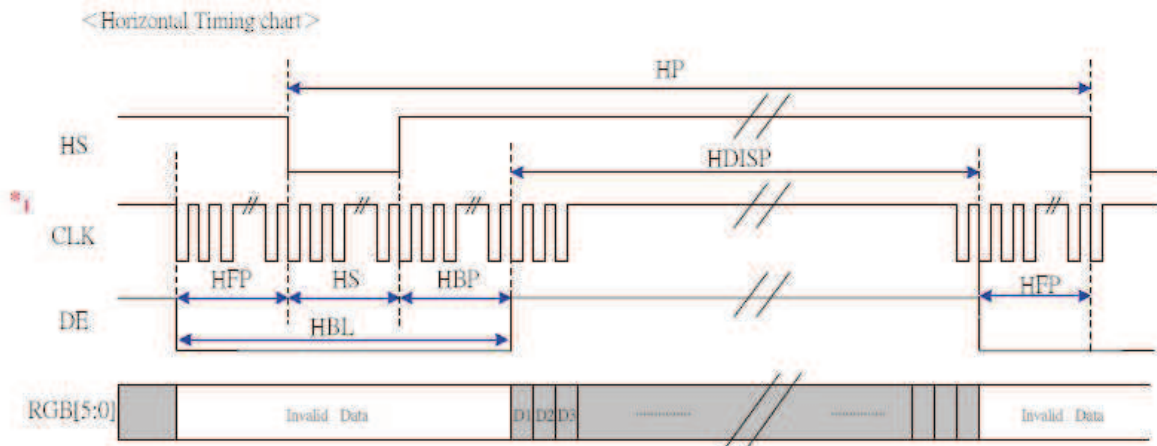

Figure 3-1 : Vertical timing of TD028TTEC1



Note: The frequency of CLK should be continued whether in display or blank region to ensure IC operating normally.

Figure 3-2 : Horizontal timing of TD028TTEC1

1. Power up the system platform and assert the RESET# signal ('L' state) for a minimum of 100us to reset the controller.
2. Configure SSD1961's PLL frequency

$$\text{VCO} = \text{Input clock} \times (\text{M} + 1)$$

$$\text{PLL frequency} = \text{VCO} / (\text{N} + 1)$$

*** Note :**

1. $250\text{MHz} < \text{VCO} < 800\text{MHz}$
PLL frequency $< 110\text{MHz}$
2. For a 10MHz input clock to obtain 100MHz PLL frequency, user cannot program $\text{M} = 19$ and $\text{N} = 1$. The closet setting in this situation is setting $\text{M} = 29$ and $\text{N} = 2$, where $10 \times 30 / 3 = 100\text{MHz}$.
3. Before PLL is locked, SSD1961/2/3 is operating at input clock frequency (e.g. 10MHz), registers programming cannot be set faster than half of the input clock frequency (5M words/s in this example).

Example to program SSD1961 with $\text{M} = 29$, $\text{N} = 2$, $\text{VCO} = 10\text{M} \times 30 = 300\text{MHz}$, PLL frequency = $300\text{M} / 3 = 100\text{MHz}$

```
WRITE COMMAND "0xE2"
WRITE DATA "0x1D"      (M=29)
WRITE DATA "0x02"      (N=2)
WRITE DATA "0x54"      (Dummy Byte)
```

3. Turn on the PLL

```
WRITE COMMAND "0xE0"
WRITE DATA "0x01"
```
4. Wait for 100us to let the PLL stable and read the PLL lock status bit.

```
Wait 100us
READ COMMAND "0xE4" (Bit 2 = 1 if PLL locked)
```
5. Switch the clock source to PLL

```
WRITE COMMAND "0xE0"  
WRITE DATA "0x03"
```

6. Software Reset

```
WRITE COMMAND "0x01"
```

7. Configure the dot clock frequency

Dot clock Freq = PLL Freq x (LCDC_FPR + 1) / 2²⁰

For example,

```
22MHz = 100MHz * (LCDC_FPR+1) / 220  
LCDC_FPR = 230685 = 0x3851D
```

```
WRITE COMMAND "0xE6"  
WRITE DATA "0x03"  
WRITE DATA "0x85"  
WRITE DATA "0x1D"
```

8. Configure the LCD panel

- a. Set the panel size to 480 x 640 and polarity of LSHIFT, LLINE and LFRAME to active low

```
WRITE COMMAND "0xB0"  
WRITE DATA "0x0C" // 18bit panel, disable dithering, LSHIFT: Data latch in rising edge,  
// LLINE and LFRAME: active low  
  
WRITE DATA "0x00" // TFT type  
WRITE DATA "0x01" // Horizontal Width: 480 - 1 = 0x1DF  
WRITE DATA "0xDF"  
WRITE DATA "0x02" // Vertical Width : 640 - 1 = 0x27F  
WRITE DATA "0x7F"  
WRITE DATA "0x00" // dummy for TFT
```

- b. Set the horizontal period

```
WRITE COMMAND "0xB4" // Horizontal Display Period  
WRITE DATA "0x02" // HT: horizontal total period (display + non-display) - 1 = 520-1 =  
// 519 = 0x0207  
WRITE DATA "0x07"  
WRITE DATA "0x00" // HPS: Horizontal Sync Pulse Start Position = Horizontal Pulse  
// Width + Horizontal Back Porch = 16 = 0x10  
WRITE DATA "0x10"  
WRITE DATA "0x07" // HPW: Horizontal Sync Pulse Width - 1 = 8-1 = 7  
WRITE DATA "0x00" // LPS: Horizontal Display Period Start Position = 0x0000  
WRITE DATA "0x00"  
WRITE DATA "0x00" // LPSPP: Horizontal Sync Pulse Subpixel Start Position(for serial  
// TFT interface). Dummy value for TFT interface.
```

- c. Set the vertical period

```
WRITE COMMAND "0xB6" // Vertical Display Period  
WRITE DATA "0x02" // VT: Vertical Total (display + non-display) Period - 1  
// = 647 = 0x287  
WRITE DATA "0x87"  
WRITE DATA "0x00" // VPS: Vertical Sync Pulse Start Position =  
// Vertical Pulse Width + Vertical Back Porch = 2+2 = 4  
WRITE DATA "0x04"  
WRITE DATA "0x01" // VPW: Vertical Sync Pulse Width - 1 = 1  
WRITE DATA "0x00" // FPS: Vertical Display Period Start Position = 0  
WRITE DATA "0x00"
```

9. Set the back light control PWM clock frequency

PWM signal frequency = PLL clock / (256 * (PWMF[7:0] + 1)) / 256

```
WRITE COMMAND "0xBE" // PWM configuration
WRITE DATA "0x08" // set PWM signal frequency to 170Hz when PLL frequency is 100MHz
WRITE DATA "0x80" // PWM duty cycle (50%)
WRITE DATA "0x01" // 0x09 = enable DBC, 0x01 = disable DBC
```

10. Turn on the display

```
WRITE COMMAND "0x29" // display on
```

11. Configure the frame buffer

a. Setup the frame buffer vertical addressing range to "1 to 480"

```
WRITE COMMAND "0x2A" // set column address
WRITE DATA "0x00" // SC: 0 = 0x0000
WRITE DATA "0x00"
WRITE DATA "0x01" // EC: 480 - 1 = 479 = 0x01DF
WRITE DATA "0xDF"
```

b. Setup the frame buffer horizontal address range to "1 to 640"

```
WRITE COMMAND "0x2B" // set page address
WRITE DATA "0x00" //SP: 0 = 0x0000
WRITE DATA "0x00"
WRITE DATA "0x02" // EP: 640 - 1 = 639 = 0x027F
WRITE DATA "0x7F"
```

12. Setup the addressing mode to rotate mode

- Note 1: In this example, the screen is assumed to be presented as landscape mode. Skip this step for portrait mode.
- Note 2: If Rotation function is enable, please make sure the required display data can write to the frame buffer within the non-display period before the LCD refresh to prevent LCD outputting a corrupted picture. Please refer to Section 7 for detail description

```
WRITE COMMAND "0x36" // set address_mode
WRITE DATA "0x60" // bit 5 is column page swap (rotate mode), bit 6 is optional.
```

13. Setup the MCU interface for 18-bit data write

```
WRITE COMMAND "0xF0" // mcu interface config
WRITE DATA "0x04" // 18 bit interface
```

* Note : The un-used data bus will be driven to ground by SSD1961, so don't connect the un-used data bus to MCU.

14. Start to write the data to frame buffer with command "write_memory_start"

```
WRITE COMMAND "0x2C" // write memory start
WRITE DATA "....." // 640 x 480 display data
```

3.2 Addition Setting for Serial RGB panel

Please refer to the Section 3.1 for the initial setting:

The initial state setting, PLL start up, data write are same as parallel mode except the following.

Example Panel information:

Pclk: 20-30 MHz

Critical setting:

Horizontal Total, HT = 1716
Horizontal Width, HDP = 320 x 3 = 960
Horizontal Front Porch, HFP = 244
Horizontal Pulse Width, HPW = 128

Vertical Total, VT = 255
Vertical Width, VDP = 240
Vertical Front Porch, VFP = 4
Vertical Pulse Width, VPW = 4

1. Configure the dot clock frequency

The required clock of serial RGB panel is 4 times as parallel mode no matter with or without dummy clock, the clock setting needed to be set 4 times faster to keep the refresh rate as parallel mode.

Dot clock Freq = PLL Freq x (LCDC_FPR + 1) / 2²⁰ *4

Since the Dot clock Frequency is 22MHz in Section 3.1, so no need to change this setting.

2. Configure the panel size to 320 x 240 serial RGB and polarity of LLINE and LFRAME to active high

RGB sequence needs to set for different serial RGB panel configuration. No different setting between parallel and serial RGB panel

```
WRITE COMMAND "0xB0"  
WRITE DATA "0x04           // configure polarity of LLINE and LFRAME  
WRITE DATA "0x40           // serial RGB without dummy clock  
WRITE DATA "0x01           // 0x13F = 320 - 1  
WRITE DATA "0x3F  
WRITE DATA "0x00           // 0x0EF = 240 -1  
WRITE DATA "0xEF  
WRITE DATA "0x03           //Panel with odd RGB & even BGR sequence
```

3. Set the front porch, back porch

```
WRITE COMMAND "0xB4           // horizontal display period stuff  
WRITE DATA "0x02  
WRITE DATA "0x3B           // total 1716 clocks  
WRITE DATA "0x00  
WRITE DATA "0x51           // non-display period =244 clocks (HPS)  
WRITE DATA "0x2A           // horizontal sync pulse width = 128 clocks (HPW) (0x2A+1) * 3=128  
WRITE DATA "0x00  
WRITE DATA "0x01  
WRITE DATA "0xAF
```

4. Set the vertical blanking interval, vertical scanning start position

```
WRITE COMMAND "0xB6           // vertical display period stuff
WRITE DATA "0x00
WRITE DATA "0xFF           // total Lline= 255
WRITE DATA "0x00
WRITE DATA "0x02           // non- display period =4 lines
WRITE DATA "0x03           // vertical sync pulse width = 4 lines
WRITE DATA "0x00
WRITE DATA "0x00
```

3.3 Deep Sleep Mode

SSD1961/2/3 supports deep sleep mode for power saving. To push SSD1961/2/3 entering deep sleep mode, the following statements are required to be programmed to SSD1961/2/3 registers:

1. Write command to enter sleep mode

WRITE COMMAND "0x10"

External LCD signals and all internal clocks would be stopped.

2. Write command set deep sleep

WRITE COMMAND "0xE5"

PLL would be stopped.

3. Stop CLKIN (reference input clock) for power consumption

3.4 Wake Up

1. To wake up SSD1961/2/3, do two dummy reads to SSD1961/2/3.
2. Wait for 100us to let the PLL stable and read the PLL lock status bit.

Wait 100us

READ COMMAND "0xE4" (Bit 2 = 1 if PLL locked)

3. Turn on the display by writing:

WRITE COMMAND "0x11"

4. Wait for 5ms

4 DYNAMIC BACKLIGHT CONTROL

Dynamic backlight control (DBC) is a unique feature of SSD1961/2/3 to reduce the power consumption of the luminance source. Content grey level scale can be increased while simultaneously lowering brightness of the backlight to achieve same perceived brightness.

The adjusted grey level scale and the power consumption reduction depend on the content of the image.

Nowadays, backlight power consumption is a major concern in portable devices. The display backlight is the single largest power consumer in a typical portable device. It account for around 30-50% of the battery drain when the backlight is fully ON.

By deploying DBC, backlight power can be reduced up to 50%.

DBC offers a balanced solution between power saving, image quality and hardware cost.

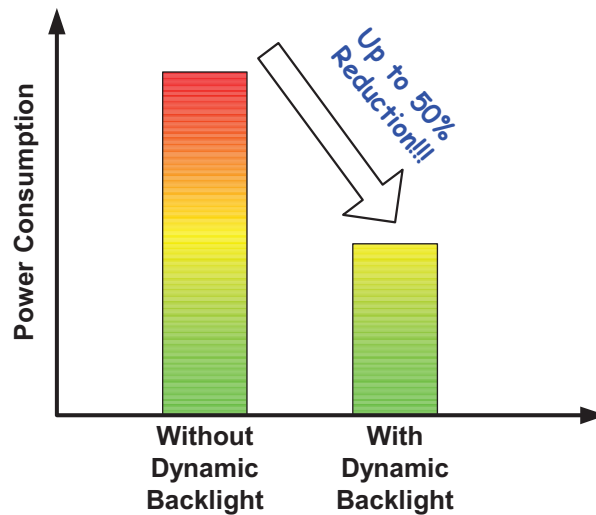

Figure 4-1 : Power comparison of DBC

SSD1961/2/3 supports four different PWM modes, included normal power level and 3 user defined power saving levels during DBC enabled.

1. Off Mode:

DBC functionality is totally off.

2. Conservative Mode

Optimized for UI image. Less power reduction without image quality degradation. Target power consumption reduction ratio: 10% or less.

3. Normal Mode

Optimized for still picture. Some image quality degradation would be acceptable. Target power consumption reduction ratio: more than 30%.

4. Aggressive Mode

Optimized for moving image. Focusing on the biggest power reduction with image quality degradation. Target power consumption reduction ratio: more than 30%

Figure 4-2: DBC Example - Original Image



Figure 4-3: DBC Example - Conservative Mode (19% backlight saved)



Figure 4-4: DBC Example - Normal Mode (31% backlight saved)



Figure 4-5: DBC Example - Aggressive Mode (50% backlight saved)



4.1 Hardware Requirement

To benefit from DBC, simply connects SSD1961/2/3's PWM to system backlight driver as shown in Figure 4-6.

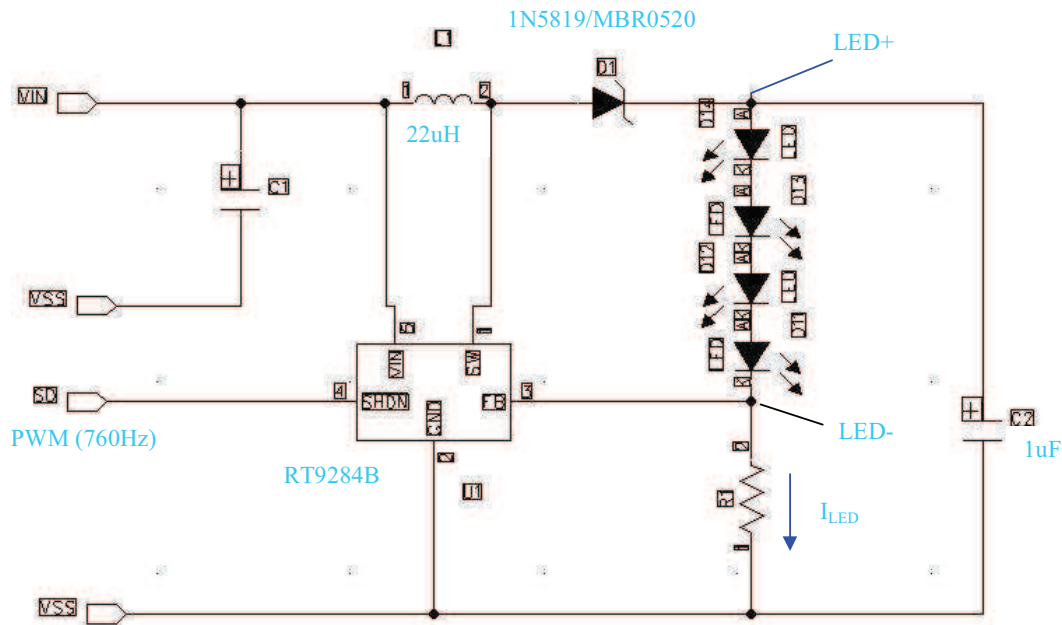

Figure 4-6: Example of hardware connection to benefit DBC

4.2 Procedures for setting up DBC

1. Choose a LED driver which support PWM with frequency from 100Hz to 1kHz.
2. Initialize Dynamic Backlight Control Parameters
 - a. Choose the PWM frequency by set_pwm_conf (0xBE) PWMF[7:0]

$$\text{PWM signal frequency} = \text{PLL clock} / (256 * (\text{PWMF}[7:0] + 1)) / 256$$
 - b. To set manual brightness level, by set_pwm_conf (0xBE) D[7:0]
 - c. To set Minimum Brightness, by set_pwm_conf (0xBE) E[7:0]
 - d. To set prescaler of Transition Effect, by set_pwm_conf (0xBE) F[3:0]

The following statements show an example initializing PWM module for VGA resolution :

```

WRITE COMMAND "0xBE"
WRITE DATA "0x01" // set PWM signal frequency to 760Hz when PLL frequency is 100MHz
WRITE DATA "0xFF" // Dummy for DBC enable
WRITE DATA "0x09" // PWM enable and controlled by DBC
WRITE DATA "0xFF" // DBC manual brightness
WRITE DATA "0x00" // DBC minimum brightness
WRITE DATA "0x00" // Brightness prescaler
  
```

5. Set the power saving level for the 3 user defined power saving modes of Conservative mode, Normal mode and Aggressive mode.

For example of VGA :

```

WRITE COMMAND "0xD4"
WRITE DATA "0x00"
WRITE DATA "0x16" //MSB of programming value for Conservative mode(10% of Power Saving)
WRITE DATA "0x80" //LSB of programming value for Conservative mode(10% of Power Saving)
WRITE DATA "0x00"
WRITE DATA "0x38" //MSB of programming value for Normal mode(25% of Power Saving)
WRITE DATA "0x40" //LSB of programming value for Normal mode(25% of Power Saving)
WRITE DATA "0x00"
WRITE DATA "0x87" //MSB of programming value for Aggressive mode(60% of Power Saving)
WRITE DATA "0x00" //LSB of programming value for Aggressive mode(60% of Power Saving)

```

The value written in each power level varies with the LCD panel resolution and user defined power saving percentage. The value equation is calculated by:

$$\text{Screen Width(W) x Screen Height(H) x 3 (RGB) / 16 x Power saving percentage.}$$

Screen Width	Screen Height	% of Power Saving	Programming Value
640	480	10%	0x1680
640	480	25%	0x3840
640	480	60%	0x8700

Table 4-1: Examples of programming value

6. Start to use DBC

For every time changing power saving level, SSD1961 is required to be programmed by the following command. DATA value varies depending on required backlight brightness.

- a. Select the power saving mode by set_dbc_conf (0xD0) A[3:2]
- b. To enable Manual Brightness, by set_dbc_conf (0xD0) A[6] to 0.
- c. To enable Transition Effect, by set_dbc_conf (0xD0) A[5] to 1.
- d. Enable DBC by set_dbc_conf (0xD0) A[0].

For example to use Aggressive mode :

```

WRITE COMMAND "0xD0"
WRITE DATA "0x0D" // Manual Brightness enable, Transition Effect disable, Aggressive DBC
enable

```

5 Use GPIO as SPI signals

This section introduces how to use GPIO of SSD196x to implement SPI.

For example,

SPI interface : 9 bit 3 wire (1 bit for data/command, 8 bit for data)

SCK : GPIO0
CSB : GPIO1
SDO : GPIO2

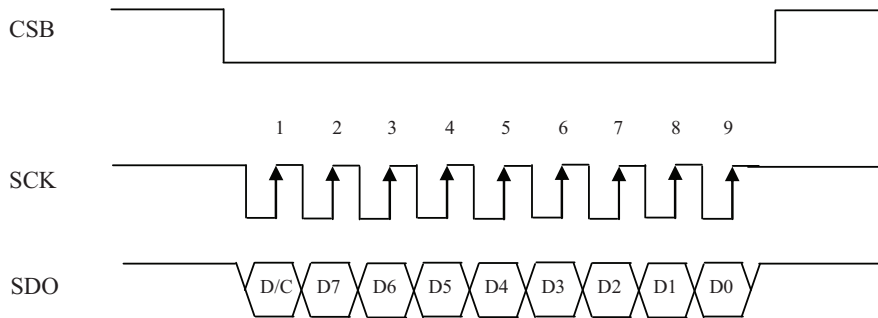

Figure 5-1: Output of GPIO signals

Program code description:

//ssd196x_write(0, 0xba) means WRITE COMMAND “0xba” to SSD196x

//ssd196x_write(1, 0x0f) means WRITE DATA “0x0f” to SSD196x

5.1 Procedure to setup the GPIO

1. Configure the GPIOs as output

```
ssd196x_write(0, 0xb8); // config gpio[3:0] as output
ssd196x_write(1, 0x0f);
ssd196x_write(1, 0x01);
```

```
ssd196x_write(0, 0xba); // set GPIO[3:0] to high first.
ssd196x_write(1, 0x0f);
```

2. Then use the following function to implement SPI

```

/*****
* void spi_write(INT16 dc, INT16 data)
*
* Description:
*
* Will send out 9 bit data(1 bit for data/command, 8 bit for data)
*
*****/

#define GPIO2 0x4
#define GPIO1 0x2
#define GPIO0 0x1

```

```

#define SDO GPIO2
#define CSB GPIO1
#define SCK GPIO0

void spi_write(INT16 dc, INT16 data)
{
    INT16 i;

    // Send 1 bit data/command ("1" for data, "0" for command)
    if(dc)
    {
        //Send '1' for D/C bit
        ssd196x_write(0, 0xba);
        ssd196x_write(1, ((~SCK) & (~CSB)) | SDO); //CLK = 0, CSB=0, SDO = 1
        ssd196x_write(0, 0xba);
        ssd196x_write(1, SCK | (~CSB) | SDO); //CLK = 1, CSB=0, SDO = 1
    }
    else
    {
        //Send '0' for D/C bit
        ssd196x_write(0, 0xba);
        ssd196x_write(1, (~SCK) & (~CSB) & (~SDO)); //CLK = 0, CSB=0, SDO = 0
        ssd196x_write(0, 0xba);
        ssd196x_write(1, (SCK) | (~CSB) & (~SDO)); //CLK = 1, CSB=0, SDO = 0
    }

    // Send 8 bit data (MSB send first)
    for(i = 0; i < 8; i++)
    {
        if(data & (1<<(7-i)))
        {
            // Send 1
            ssd196x_write(0, 0xba);
            ssd196x_write(1, ((~SCK) & (~CSB)) | SDO); //CLK = 0, CSB=0, SDO = 1
            ssd196x_write(0, 0xba);
            ssd196x_write(1, SCK | (~CSB) | SDO); //CLK = 1, CSB=0, SDO = 1
        }
        else
        {
            // Send 0
            ssd196x_write(0, 0xba);
            ssd196x_write(1, (~SCK) & (~CSB) & (~SDO)); //CLK = 0, CSB=0, SDO = 0
            ssd196x_write(0, 0xba);
            ssd196x_write(1, (SCK) | (~CSB) & (~SDO)); //CLK = 1, CSB=0, SDO = 0
        }
    }

    ssd196x_write(0, 0xba); // output all GPIO[3:0] high
    ssd196x_write(1, 0x0f);

    for(i = 0; i < 20000; i++); // dummy loop
}

```

3. Then use the following function call to send out SPI command or data

Example :

Write command **0x28** to LCD driver

```
spi_write(0, 0x28);
```

Write command with 2 parameters **0x2c, 0x10, 0x20** to LCD driver

```
spi_write(0, 0x2c);
```

```
spi_write(1, 0x10);
```

```
spi_write(1, 0x20);
```

6 Use GPIO as MISC signals

There are four general purpose signals (GPIO0-3) that can act as the timing ASIC for the TFT panel. These signals are controlled by four signal generators (GEN0-3) which the rise, fall position and period can be programmed. The output of the signal generator can be toggle by pixel clock, by line or by frame. 3 sources (SRC1-3) out of the 4 signal generators are mixed by ROP (raster operation) and connect to one of the 4 GPIO ports. By doing ROP between the output of generators, the user can generate different kinds of timing signals that fulfill the requirements of different panel. ROP allow bitwise Boolean operation (e.g. AND, OR) to the 3 sources.

Toggle by pixel clock (toggle mode = 01)

The rise, fall and period are in unit of pclk.

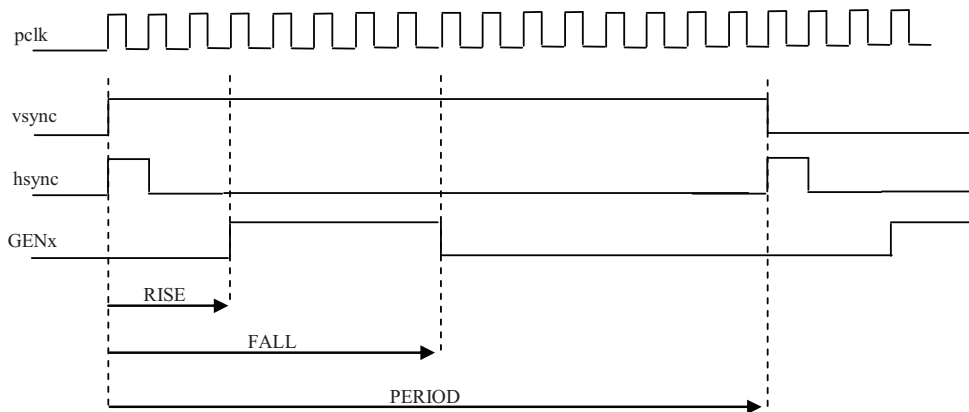

Toggle by line (toggle mode = 10)

The rise, fall and period are in unit of hsync.

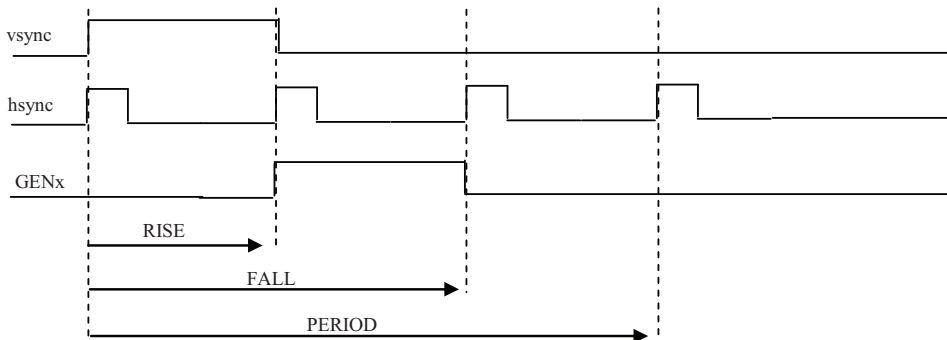

Toggle with frame (toggle mode = 11)

The rise and fall are in unit of hsync. The pattern repeats and resets at every frame. This mode will ignore the PERIOD field.

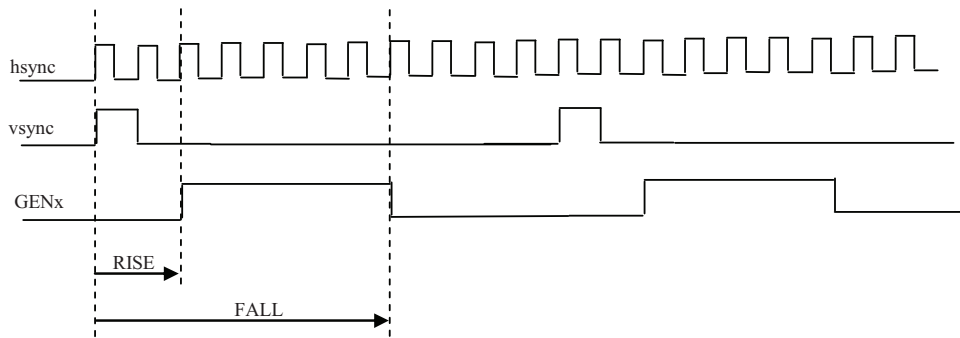

For example, GPIOx will be generated by “OR” the src1, src2 and src3 together as followings.



The ROP value is based on the below “OR” truth table:

Src1	Src2	Src3	ROP
0	0	0	0 (LSB)
0	0	1	1
0	1	0	1
0	1	1	1
1	0	0	1
1	0	1	1
1	1	0	1
1	1	1	1 (MSB)

```

SRC1 = 00    // GEN0
SRC2 = 01    // GEN1
SRC3 = 10    // GEN2
ROP = 1111 1110

```

6.1 Procedure to setup the GPIO

Example: Set GPIO0 with output after 2 pclk of vsync (rising position=2), signal pulse width is 1 pclk (falling position = 2+1 = 3) and repeat after 8 pclk (period = 8) using generator 0.

1. Set GPIO Configuration

```

WRITE COMMAND "0xB8"
WRITE DATA "0xFF"           //set GPIO0, 1, 2, 3 as output and controlled by LCDC
WRITE DATA "0x01"           //set GPIO0 as normal GPIO

```

2. Set LCD Gen0

Reset generator 0 with VSync
 GPIO0 output after 2 pclk(rising position=2), signal period is 1 pclk (falling position = 2+1 = 3)and repeat after 8 pclk

```

WRITE COMMAND "0xC0"
WRITE DATA "0x80" // reset generator 0 with VSync
WRITE DATA "0x00" //set generator 0 falling position = 2+1 = 3
WRITE DATA "0x02"
WRITE DATA "0x00" //set generator 0 rising position = 1+1 = 2
WRITE DATA "0x01"
WRITE DATA "0x08" //Generator 0 toggle mode as toggle by pixel clock (LSHIFT)
WRITE DATA "0x07" //set generator 0 toggle mode with pclk and period = 8-1 = 7
  
```

3. Set GPIO0 ROP

```

WRITE COMMAND "0xC8"
WRITE DATA "0x00" //Select GEN0 for Src1, 2, 3 and then muxed for GPIO0
WRITE DATA "0xFE" // ROP operation between source 1, 2 and 3 for GPIO0
  
```

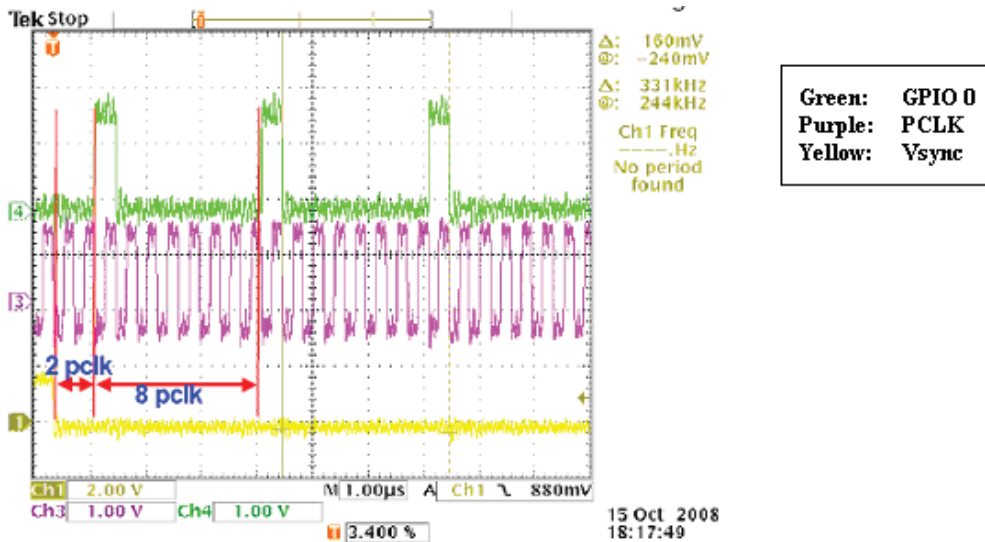

Figure 5-1: GPIO MISC signal

To set more GPIO, please refer to following table

	write command
LCD Generator 0	0xC0
LCD Generator 1	0xC2
LCD Generator 2	0xC4
LCD Generator 3	0xC6
	write command
GPIO0 with respect to the LCD signal generators using ROP operation	0xC8
GPIO1 with respect to the LCD signal generators using ROP operation	0xCA
GPIO2 with respect to the LCD signal generators using ROP operation	0xCC

GPIO3 with respect to the LCD signal generators using ROP operation	0xCE
---	------

7 Example for rotation display

Condition:

- Display resolution: 320 x 240
- 24 bit 8080 MCU interface
- 24bit color for LCD data
- 60Hz refresh rate
- 40ns for a MCU write cycle ($t_{PWCSL} + t_{PWCSH}$)
- 196x display window setting: 240 x 320 with rotation function turn on

Figure 7-1 : The figure illustrates the panel scan direction and SSD196X memory mapping

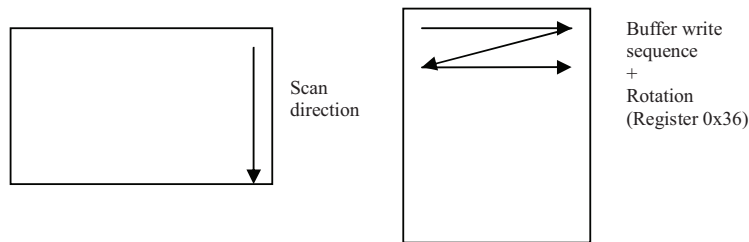

The frame buffer must be filled for a frame before the LCD panel refresh to avoid cropping line symptom during display data update.

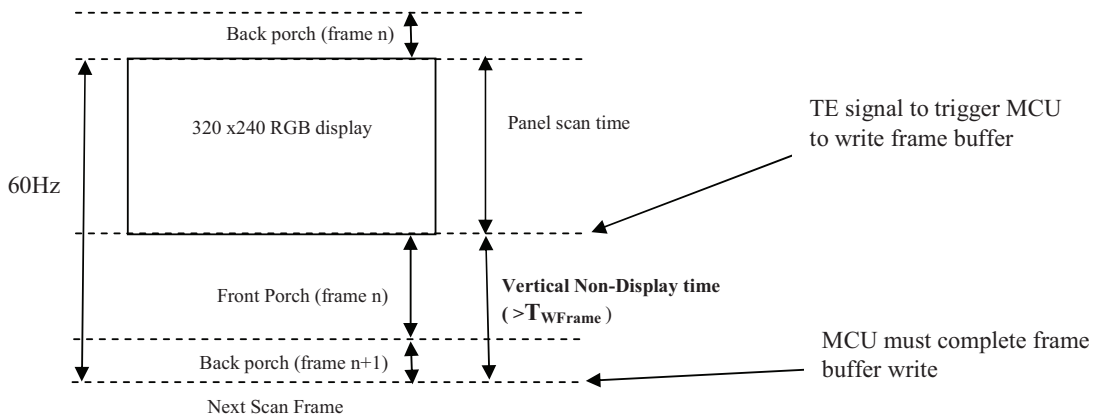

1) To calculate the time to complete writes a full display frame, T_{WFrame} . (For 1 MCU cycle to write one pixel data)

$$\begin{aligned}
 T_{WFrame} &= \text{Total number of data need to write} * \text{MCU write cycle time} \\
 &= 320 \times 240 \times 40\text{ns} \\
 &= 3.07 \text{ ms}
 \end{aligned}$$

2) To calculate the non-display period time for writing display frame, $T_{Non-display}$.

$$\begin{aligned}
 T_{Non-display} &= (1 / 60) * (\text{Vertical non-display line} / \text{Vertical line Total}) \\
 &= (1 / 60) * (55 / (240+55)) \quad // \text{ for vertical non-display} = 55 \\
 &= 3.1 \text{ ms}
 \end{aligned}$$

* Please refer to the LCD panel specification for the maximum number of vertical non-display line supported

If $T_{WFrame} < T_{Non-display}$, TE signal can be used to control the frame data write time for SSD196X rotation application to avoid cropping lines when data updating.

In the above example, minimum 55 vertical non-display lines are needed to fulfill the time for MCU display data written.

Solomon Systech reserves the right to make changes without notice to any products herein. Solomon Systech makes no warranty, representation or guarantee regarding the suitability of its products for any particular purpose, nor does Solomon Systech assume any liability arising out of the application or use of any product or circuit, and specifically disclaims any, and all, liability, including without limitation consequential or incidental damages. “Typical” parameters can and do vary in different applications. All operating parameters, including “Typical” must be validated for each customer application by the customer’s technical experts. Solomon Systech does not convey any license under its patent rights nor the rights of others. Solomon Systech products are not designed, intended, or authorized for use as components in systems intended for surgical implant into the body, or other applications intended to support or sustain life, or for any other application in which the failure of the Solomon Systech product could create a situation where personal injury or death may occur. Should Buyer purchase or use Solomon Systech products for any such unintended or unauthorized application, Buyer shall indemnify and hold Solomon Systech and its offices, employees, subsidiaries, affiliates, and distributors harmless against all claims, costs, damages, and expenses, and reasonable attorney fees arising out of, directly or indirectly, any claim of personal injury or death associated with such unintended or unauthorized use, even if such claim alleges that Solomon Systech was negligent regarding the design or manufacture of the part.

All Solomon Systech Products complied with six (6) hazardous substances limitation requirement per European Union (EU) “Restriction of Hazardous Substance (RoHS) Directive (2002/95/EC)” and China standard “电子信息产品污染控制标识要求 (SJ/T11364-2006)” with control Marking Symbol . Hazardous Substances test report is available upon requested.

<http://www.solomon-systech.com>