

# JM Precision

Revision 2

## Pre-loading for 608 sized bearings

**These bearings are supplied either oiled or dry. In either case they must be thoroughly cleaned and dried prior to use. Any dirt left in the bearings prior to fitting can cause premature failure and/or noisy running.**

In Order for these bearings to operate correctly at high rotational speeds it is very important that the correct level of pre-loading is used and that an oil mist lubrication system is provided.

The correct level of pre-loading will vary depending on application but should normally be in the range 12 – 25N.

Because these bearings are full compliment the inner race is not symmetrical so the pre-loading forces must be applied as indicated in Fig 1 below.

The inner race is narrower on one side than on the other and the arrows indicate the direction of the pre-loading forces.

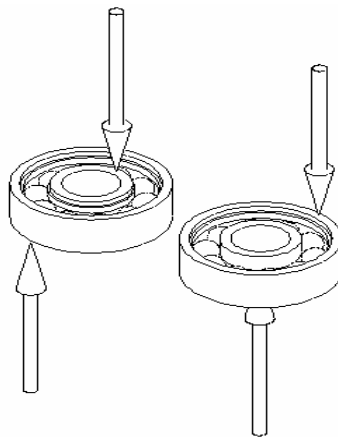

**Fig 1**

## Bearing Running

Full compliment bearings do not have a cage to spread the balls evenly around the bearing races so they will be randomly spaced while stationary or at low rotational speeds. They therefore exhibit generally higher rotational resistance than standard caged bearings until a minimum rotational speed is reached at which point the balls will spread themselves evenly around the bearing races and provide a very low running resistance. Because there is no cage to drag on the balls and create imbalance forces these types of bearings can be safely run at much higher speeds and temperatures than standard caged bearings. They do however have the disadvantage that they cannot be used in low speed applications where the rotational speed will be below around 5000 – 10000rpm. At low speed and unpreloaded operation the bearings will run poorly and cause noise and vibration.